



A & C Plastics, Inc.
6135 Northdale
Houston, TX
77087-5095

Phone Numbers
Sales: 713.645.4915
Fax: 1.800.627.5899
Toll Free: 1.800.231.4175

Email Addresses
plastic@acplasticsinc.com
sales@acplasticsinc.com

Macrolux Multiwall Polycarbonate Sheet

STORAGE REQUIREMENTS

MACROLUX crates or sheets should be stored in warehouse areas not exposed to direct heat or light which could make the removal of protective film difficult. Supported, sloped stacking is recommended, but sheets may be stacked up to 3' high on a flat, even, supported surface.

PROTECTIVE FILM

All MACROLUX panels are supplied with a protective PE film which should be kept on until the panel is fastened. The U.V. protected side is to be faced towards the sun and is marked with a white printed film or light blue film with a sticker saying MACROLUX co-extruded thermoglazing.

FABRICATION

MACROLUX won't crack or split when cut or drilled. Able to withstand extreme abuse, its impact strength is 200 times greater than glass and 10 times greater than acrylic.

MACROLUX may be cut using a circular saw with a fine tooth blade for sizes up to 16mm, or with a razor knife cut on both sides of the material. Compressed air may be used to remove dust from the channels.

Allow for proper expansion in all drilled holes.

Do not drill within 1 1/2" from the edge of the MACROLUX sheet.

When fastening screws, do not tighten below the surface of the panel.

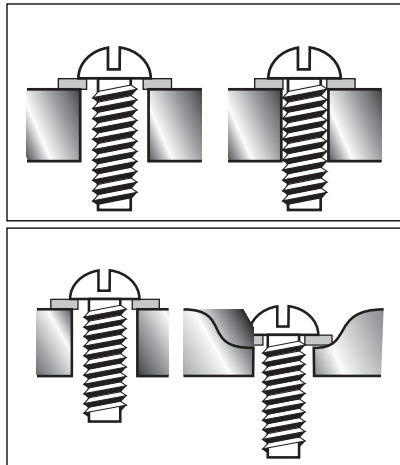

INSTALLATION

Stiff fixing by means of adhesive or putty is to be avoided. If using sealants, contact your CO-EX distributor for recommended sealants.

Exposed top and bottom ends of a sheet must always be sealed by means of the proper polycarbonate "U" profiles or an adhesive aluminum tape to prevent dust and dirt penetrating inside the ribs.

It is advisable to drill small weep holes every 12 inches in the bottom "U" profile for condensation drainage.

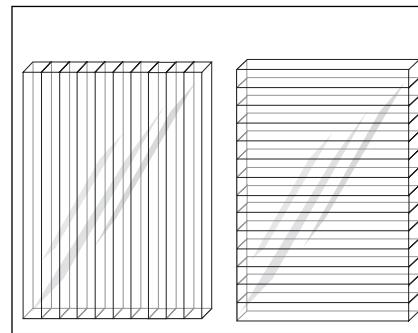
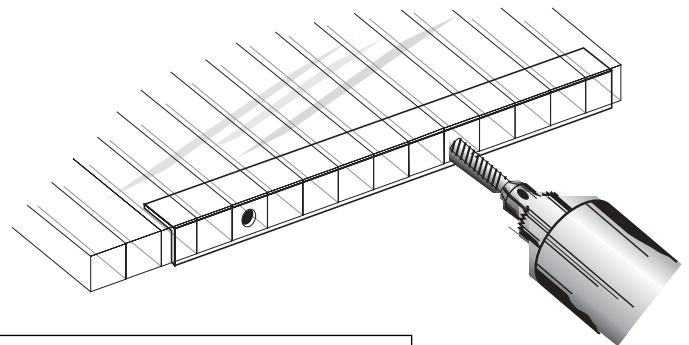

Extruded ribs shall be installed in a vertical direction for drainage.

Glazing sheets should be joined by MACROLUX extruded polycarbonate profiles and be in-

stalled with their protective U.V. stabilized surface towards the exterior. MACROLUX should not be used with PVC profiles, however, a variety of aluminum systems may be used. Consult with your local CO-EX Distributor for approved systems.

The use of horizontal bars should be avoided. Instead, order MACROLUX in the proper length (up to 39 ft.)

For proper application of MACROLUX in roofing conditions, a slope of at least 5° is required.

BENDING RADII

MACROLUX panels can be readily cold formed to many bending radii and can be fabricated on site to precise dimensions. It is important to avoid over tensing of the sheet, therefore, the minimum bending radius must be 150 times the thickness of the panel. Minimum Bending Radius = Ft./1 inch.

SHEET THICKNESS	4 mm	4.5 mm	6 mm	8 mm	10 mm
MIN. BEND RADIUS	1' 11"	2' 2"	2' 11"	3' 11"	4' 11"
SHEET THICKNESS	10 mm*	16 mm	16 mm*	20 mm	20 mm*
MIN. BEND RADIUS	4' 11"	7' 10"	7' 10"	9' 10"	9' 10"
* Indicates triple wall Version					

Macrolux Multiwall Polycarbonate Sheet

FASTENING

For proper point fastening, 1" neoprene bonded washers should be used with screws.

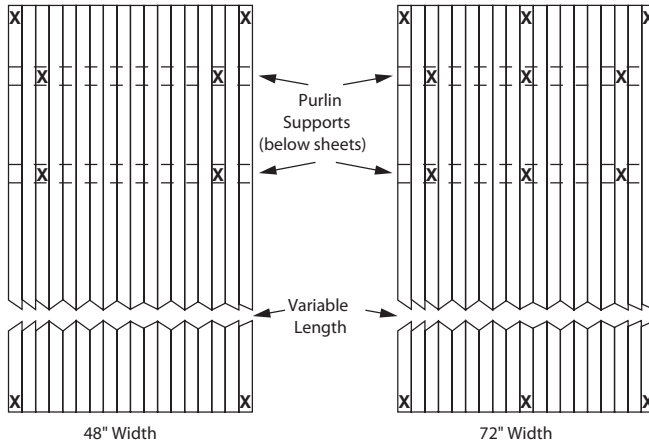

48 inch wide sheets should be fastened to supports at all four corners, and at points 6" in from the edges of each purlin support.

72 inch wide sheets should be fastened to supports at all four corners, and at points 6" in from the edges of each purlin support and in the center of the purlin supports.

THERMAL EXPANSION

Allow for thermal expansion during installation at a rate of 1/8" per 3 feet at 100° temperature differentials in both width and length of the sheet. Bronze panels will require an additional 30% space.

IMPACT RESISTANCE

Among the thermostatic products used in the building industry, MACROLUX co-extruded thermoglazing has the highest impact resistance. You can be assured that from transport to installation, MACROLUX will maintain its durability. Even when exposed to elevated temperatures over a long period of time, it will maintain its structural integrity. On-site, it will not crack or splinter, assuring you a high degree of safety.

RESISTANCE OF POLYCARBONATE TO CHEMICAL AGENTS

Polycarbonate panels are resistant to some chemicals and products and non-resistant to others. Resistance can be effected by the chemicals concentration, duration of exposure, degree of pressure and temperature at time of contact. Check with your local CO-EX distributor for complete recommendations.

LOAD RESISTANCE

This diagram is valid only when the following conditions are followed:

- Correct calculation of expansion in order to provide for the necessary allowance in the framing. The thermal expansion coefficient is 0.0000375 in/in °F.
- Install the sheets with the ribs running vertically. For bent applications, the ribs should bend, following the arch in the sheet.
- Washers and sealing materials must be compatible with polycarbonate.

RECOMMENDED LOADING

Guidelines for Selecting Sheet Thickness and Purlin Spacing (Sheet Supported on the Four Sides)

MAX. PURLIN SPACING (inches) DEFLECTION – 1"

LOAD PER GAUGE (lb./ft. ²)	4' WIDTH			
	15	30	45	60
8 mm, 5/16"	38"	28"	18"	–
10 mm, 3/8"	45"	34"	28"	12"
16 mm, 5/8"	75"	43"	36"	30"
20 mm, 3/4"	80"	48"	41"	35"

LOAD PER GAUGE (lb./ft. ²)	6' WIDTH			
	15	30	45	60
8 mm, 5/16"	36"	26"	12"	–
10 mm, 3/8"	44"	33"	27"	24"
16 mm, 5/8"	60"	40"	36"	30"

MAX. PURLIN SPACING (inches) DEFLECTION – 3"

LOAD PER GAUGE (lb./ft. ²)	4' WIDTH			
	15	30	45	60
8 mm, 5/16"	80"	54"	46"	40"
10 mm, 3/8"	96"	69"	58"	54"
16 mm, 5/8"	120"	110"	104"	84"
20 mm, 3/4"	125"	115"	109"	89"

LOAD PER GAUGE (lb./ft. ²)	6' WIDTH			
	15	30	45	60
8 mm, 5/16"	60"	44"	38"	34"
10 mm, 3/8"	80"	56"	44"	38"
16 mm, 5/8"	120"	78"	72"	62"

CLEANING

MACROLUX should be protected from abrasion by the installer. After installation, panels should be washed with mild soap or detergent and lukewarm water using only a clean sponge or soft cloth, then rinsed with clean water. Fresh paint, grease, and smeared glazing compounds may be removed before drying by rubbing lightly with a good grade of naphtha or isopropyl alcohol followed by a final wash with mild soap or detergent and final rinse.